

**INSTRUCTION
MANUAL
YO-901**

YAESU MUSEN CO , LTD.

TOKYO JAPAN.

TABLE OF CONTENTS

	(Page)
GENERAL	1
SPECIFICATIONS	2
FRONT PANEL CONTROLS	3
REAR APRON	5
INSTALLATION NOTES	6
OPERATION	7
CIRCUIT DESCRIPTION	14
MAINTENANCE & ALIGNMENT	16

YO-901 MULTISCOPE



The YO-901 is a high-performance monitoring instrument, designed for use with the FT-901DM series of amateur equipment. Built around a high-performance oscilloscope, useful for countless station measurements, the YO-901 includes a two-tone generator, provision for both RX and TX monitoring, and automatic remote switching of monitoring modes.

An exciting option for the YO-901 is a band scope, which allows instant determination of band conditions and activity.

Interface to the FT-901DM is quick and easy, with no modification required for both narrow and wide band IF monitoring. Connection cables for typical installations are included with your YO-901.

The owner is urged to read this manual in its entirety, so as to become better acquainted with the exciting new YO-901 Multiscope.

SPECIFICATIONS

RF Monitor

Frequency range: 1.8–54 MHz
 Input impedance: 50–75 ohms
 Power ranges: 10–500 watts (ANTENNA jack)
 5–100 watts (EXCITER jack)
 Input attenuator: 5 positions
 Insertion loss: 0.5 dB max.

IF Monitor

Operating frequency: 8987.5 kHz
 Sensitivity: 2 mV (p-p)/div

Vertical input

Sensitivity: 20 mV (p-p)/div
 Input attenuator: X1, X10, X100
 Frequency range: 2 Hz–4 MHz (–3 dB)
 8.5–10.7 MHz
 Input impedance: 1 M ohm, 80 pf.
 Maximum voltage: 600 volts (DC + AC peak)

Horizontal input

Sensitivity: 300 mV (p-p)/div
 Frequency range: 10 Hz–250 kHz (–3 dB)
 Input impedance: 100 K ohms, 100 pf.
 Sweep frequencies: 10 Hz–100 kHz, 4 ranges

Two-tone generator

Frequency: 1500/1900 Hz
 Output level: 20 mV (p-p)

Band Scope (Option)

Operating frequency: 8987.5 kHz
 Sensitivity: Log 50 μ V/4 DIV
 Lin 500 μ V/4 DIV
 Scanning frequency: 10 Hz
 Input impedance: 50/5 K ohms
 Power requirements: 100/110/117/200/220/234
 volts AC, 50/60 Hz
 Current consumption: 25 VA
 Size: 157 (W) x 210 (H) x 323 (D) mm
 Weight: 6.5 kg

SEMICONDUCTORS

Integrated Circuits:

MC7915CP	1	μ PC14308H	1
μ PC14312H	1		

Field-Effect Transistors:

2SK30AGR	2	2SK30AY	3
----------	---	---------	---

Silicon Transistors:

2SA733P	2	2SC1215	4
2SC752(O)	2	2SC1514	2
2SC1012A	2	2SC1815(O)	8

Germanium Diodes:

1N60	3		
------	---	--	--

Silicon Diodes:

1DZ61	8	1S1588	18
1R150	4	1S1830	2

Zener Diodes:

RD5.6EB	1	RD6.2EB	1
---------	---	---------	---

BAND SCOPE (Option)

Field-Effect Transistors:

2SK30AGR	2	3SK40	1
2SK33F	1		

Silicon Transistors:

2SA1015	2	2SC1215	3
2SA1015GR	2	2SC1815O	6
2SA1015O	1		

Germanium Diodes:

1N60	2		
------	---	--	--

Silicon Diodes:

1S1588	21		
--------	----	--	--

Varactor Diodes:

FC-52M	1		
--------	---	--	--

FRONT PANEL CONTROLS

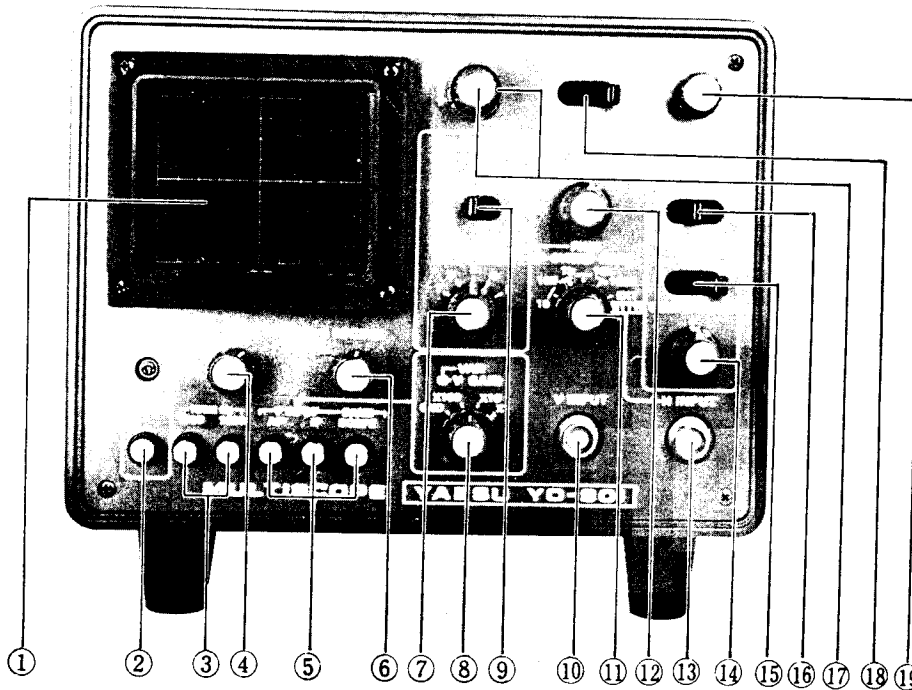

(1) SCOPE

High-resolution cathode-ray tube.

(2) POWER (ON OFF)

Push this button to apply AC power.

(3) TONE (ON OFF)

For the 1500 and 1900 Hz tone generators, an on/off switch is provided. Pushing both buttons applies both tones.

(4) INTENSITY

This control varies the brightness of the pattern on the scope screen. Excessive brightness may burn the phosphor on the face of the picture tube, so use the minimum brightness necessary for easy viewing.

(5) V INPUT, BAND SCOPE

These buttons select between AF, IF/narrow, and IF/wide input to the vertical amplifier.

(6) FOCUS

This control sets the clarity of the display trace. There may be some interaction between this control and the INTENSITY control.

(7) INPUT LEVEL

This control sets the level for the transmitter output signal monitor.

(8) V GAIN, VAR

The V GAIN sets the level for the vertical display. The VAR control allows precise setting of the gain level of the vertical amplifier.

(9) ENVEL/TRAP

This switch selects between monitoring of the transmitter output envelope and trapezoidal display (for two-tone testing).

(10) V INPUT

This is the input terminal for the vertical amplifier, for using the YO-901 as an oscilloscope (AF mode).

(11) SWEEP FREQ/FINE

These controls set the sweep frequency. At the EXT H position of the SWEEP FREQ control, horizontal input is selected, and this position can also be used for RTTY cross pattern observation. The FINE control allows fine tuning of the sweep frequency.

(12) H GAIN

This control sets the gain of the horizontal amplifier.

(13) H INPUT

This is the input terminal for the horizontal amplifier. This can be used for RTTY cross pattern monitoring, as well as general XY scope tests.

(14) CENTER FREQ

When the Band Scope option is installed, this control sets the center frequency of the monitor.

(15) WIDTH (kHz/DIV)

This control sets the bandwidth of the optional bandscope.

(16) LIN/MARK ON/LOG

This is the function switch for the optional band scope. The switch selects between linear or log display, or the internal marker generator. In the LOG position, the display is set to 3 dB/division. The marker can be used to set the center of the optional band scope.

The following accessories are included with your YO-901:

- (1) CONNECTION CABLES (see below)
 - (2) BNC PLUG (UG-88/U) 2
 - (3) SPARE FUSES 1
- (Note: when replacing fuses, use only a 1 ampere fuse.)

(17) V POS. B SCOPE

These controls determine the vertical position of the displayed pattern. The B Scope control is used only during Bandscope operation

(18) MODE

This switch sets the operating mode of the YO-901. In the AUTO mode, automatic switching is provided between transmit and receive monitoring. When only the transmit monitor or optional band scope is being used, the switch should be set appropriately.

(19) H POS.

This switch sets the horizontal position of the displayed pattern.

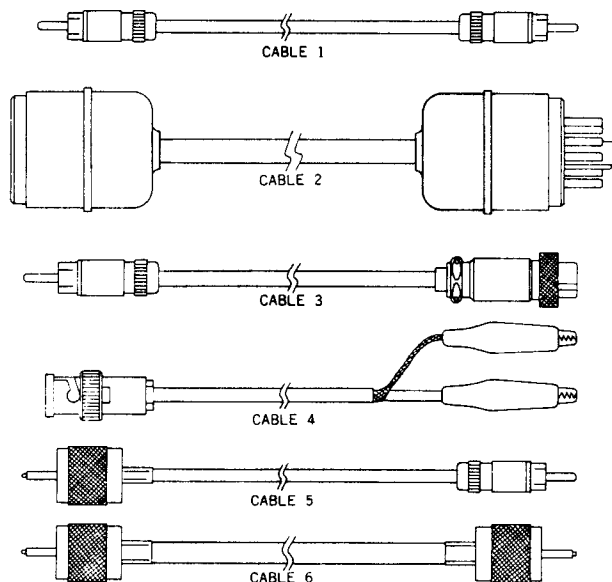

PIN 1.....HEATER	PIN 8.....GND
PIN 2.....HEATER	PIN 9.....TX, GND
PIN 7.....ALC	PIN10.....RX, GND

CABLE 2 CONNECTIONS

REAR APRON

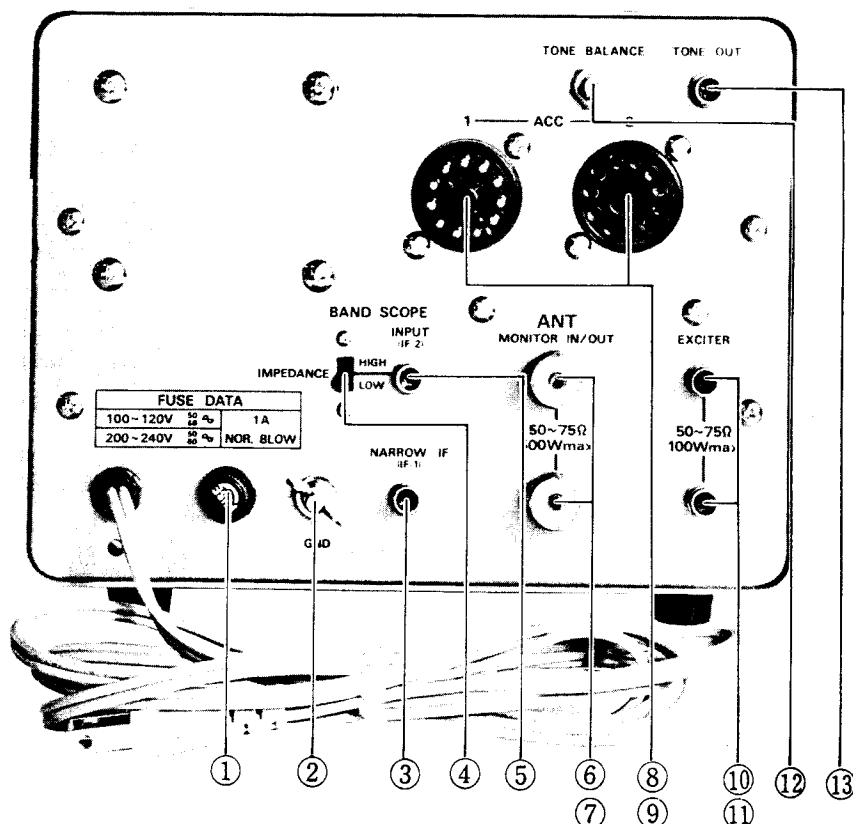

(1) FUSE

For all AC voltages, a 1 ampere fuse must be installed here. When replacing fuses, be absolutely certain to use a fuse of the proper rating. **OUR WARRANTY DOES NOT COVER DAMAGE CAUSED BY IMPROPER FUSE REPLACEMENT.**

(2) GND

For proper operation, connect this terminal to a good earth ground. This practice also will help guard against dangerous electrical shock.

(3) NARROW IF

This jack should be connected to the IF-1 terminal on the rear apron of the FT-901DM, for IF monitoring.

(4) HI/LOW

For using the optional band scope, this switch selects the input impedance. For use with the FT-901DM use the LOW position.

(5) BAND SCOPE INPUT

When the optional band scope is installed, this jack should be connected to the IF-2 jack on the rear apron of the FT-901DM.

(6)(7) ANT

These connectors are in parallel, for sampling of the transmitter output signal. Do not exceed 500 watts PEP at these terminals. **OUT WARRANTY DOES NOT COVER DAMAGE CAUSED BY USE OF A HIGHER-POWER TRANSMITTER WITH THIS EQUIPMENT.**

(8)(9) ACC

The interconnection cable to the FT-901DM should be connected to the ACC-1 jack. The ACC plug, normally inserted in the rear of the FT-901DM, should be inserted in the ACC-2 socket, to make the proper connections for heater voltage, etc.

(10)(11) EXCITER

For trapezoidal pattern monitoring, connect the exciter to these terminals. Do not exceed 100 watts at these terminals.

(12) TONE BALANCE

This control sets the level of the 1500 Hz tone. The 1900 Hz tone is fixed in amplitude.

(13) TONE OUT

This jack is the output connection for the two-tone generator.

INSTALLATION NOTES

Details for interconnection will be presented along with the discussion of each test procedure.

Power connections

The YO-901 Multiscope is designed for use throughout the world, from a variety of supply voltages. Therefore, before connecting the AC power cord to the supply, be absolutely certain that the voltage specification on the back of the Multiscope matches your local supply voltage. **OUR WARRANTY DOES NOT COVER DAMAGE CAUSED BY APPLICATION OF IMPROPER SUPPLY VOLTAGE.**

As well, the power cable should never be connected to a DC power source. **OUR WARRANTY DOES NOT COVER DAMAGE CAUSED BY APPLICATION OF DC POWER TO THE POWER JACK.**

Be certain to observe the maximum voltage allowances for the V. INPUT and H. INPUT jacks:

V. INPUT 600 volts (DC + AC peak)

H. INPUT 30 volts (DC + AC peak)

Do not exceed 100 watts of RF power at the EXCITER jack, nor 500 watts of RF power at the ANT jack. These limitations apply up to an SWR of 3:1 with respect to the 50–75 ohm range. If the SWR is above this level, these ratings are decreased significantly, because of the high voltages present on the transmission line. **OUR WARRANTY DOES NOT COVER DAMAGE CAUSED BY EXCEEDING THESE POWER LIMITATIONS.**

In order to ensure long life for your cathode-ray tube, a few simple precautions need to be observed. It is possible to burn the phosphor on the screen if an excessively bright display is used for a long time. Do not leave the display locked on a particular display mode (e.g. focus point, standby line, etc.) at maximum brightness.

When making the voltage connections to the FT-901DM ACC jack, the ACC plug supplied with the transceiver should be installed in the ACC-2 position on the rear panel of the Monitoroscope, so as to make the proper heater connections for the FT-901DM.

When setting up your station, the following precaution needs to be observed: the YO-901 should not be located immediately adjacent to a strong magnetic field, such as that which might be induced by the power transformer in a linear amplifier. Refer to Figure 1 for a demonstration of correct and incorrect configurations of station equipment.

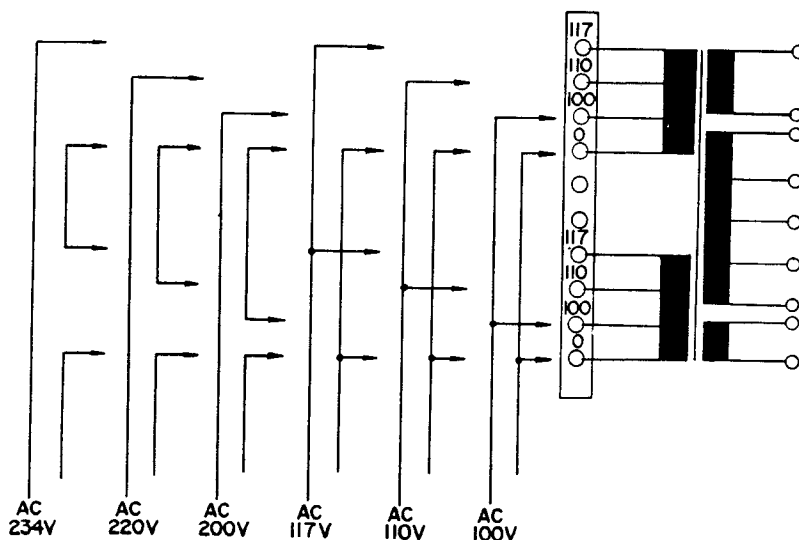

OPERATION

Prior to commencing operation, reaffirm that the voltage specification of the YO-901 is correct, and a proper fuse is installed.

Preset the controls and switches as follows:

POWER OFF
INTENSITY To the center of its range.
FOCUS To the center of its range.
V. POS To the center of its range.
H. POS To the center of its range.
VAR To the center of its range.
H. GAIN To the center of its range.
CENTER FREQ. To the center of its range.
FINE To the center of its range.
INPUT LEVEL 3
V. GAIN X 100
MODE AUTO
SWEEP FREQ. 10 Hz – 100 Hz
TONE BOTH OFF
V. INPUT AF or IF

Adjust the FOCUS control for a clear and sharp trace. There may be some interaction between this control and the INTENSITY control, so they both may require some adjustment.

Adjust the H. POS and V. POS controls to bring the trace into the center of the screen. Adjustment of the H. GAIN control will produce a horizontal line on the screen.

Operating reminder:

When making tests with the YO-901, we recommend the use of a dummy load, instead of an antenna, out of courtesy to other operators. Of course, the YO-901 may be used at all times during normal operation, but extensive tests may cause interference to other amateurs. Spectrum conservation is everyone's responsibility.

Switch the POWER switch ON. The pilot light will turn on, and after a warm-up period of approximately 10 seconds, a bright trace will appear on the screen. Adjust the INTENSITY control for a comfortable, yet not excessively bright, display.

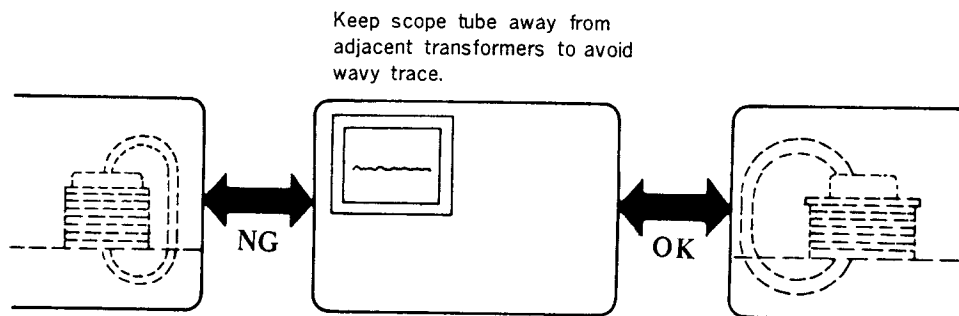

Figure 1.

TRANSMITTER/RECEIVER MONITORING

Make connections between the YO-901 and the FT-901DM as shown in Figure 2 .

I. TRANSMITTER MONITORING

- (1) Place the MODE switch in the TX MONITOR position.
- (2) Place the ENVEL/TRAP switch in the ENVEL position.
- (3) Place the INPUT level control to the position indicated in Table 1 , according to the power level being used.
- (4) For the following SSB signal evaluation tests, the SWEEP FREQ and FINE controls will provide the desired display synchronization.
- (5) For two-tone signal testing, push the 1900 and 1500 buttons. While transmitting, the correct levels for the MIC GAIN, RF PROCESSOR, and other controls can be made by referring to Figure 3 .
- (6) To set the level correctly between the two internally-generated tones, first press the 1900 Hz tone button. While transmitting, adjust the V. GAIN control until the display reaches the second division on the scale. Now turn the 1900 Hz button off, and turn on the 1500 Hz button. Rotate the TONE BALANCE control, located on the rear apron of the transceiver, until the display amplitude is the same as that observed for the 1900 Hz tone previously.

The following are typical signal waveforms observed from the transmitter when it is connected as shown in Figure 2 .

- (A) SSB signal, voice modulated, with proper adjustment. The display will become somewhat more "full" when the RF processor in the FT-901DM is activated.
- (B) SSB signal, voice modulated, with excessive mic gain or insufficient loading. Flat-topping on the waveform can be observed.
- (C) Pure, clean CW signal.
- (D) CW signal, with hum and key clicks.
- (E) SSB signal, two-tone test conditions, correctly adjusted.
- (F) SSB signal, two-tone test conditions, with carrier leakage.
- (G) SSB signal, single-tone test conditions, correctly adjusted.

OUTPUT	INPUT LEVEL	HEIGHT
5W	5	5 DIV.
15W	4	6 DIV.
100W	3	6 DIV.
100W	2	5 DIV.
500W	1	6 DIV.

Table 1 (Measured With 50 ohm Dummy Load)

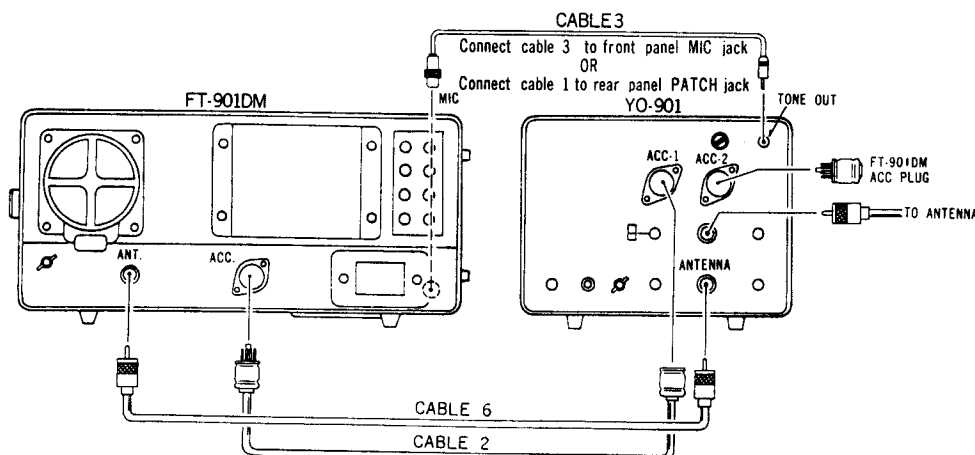

Figure 2.

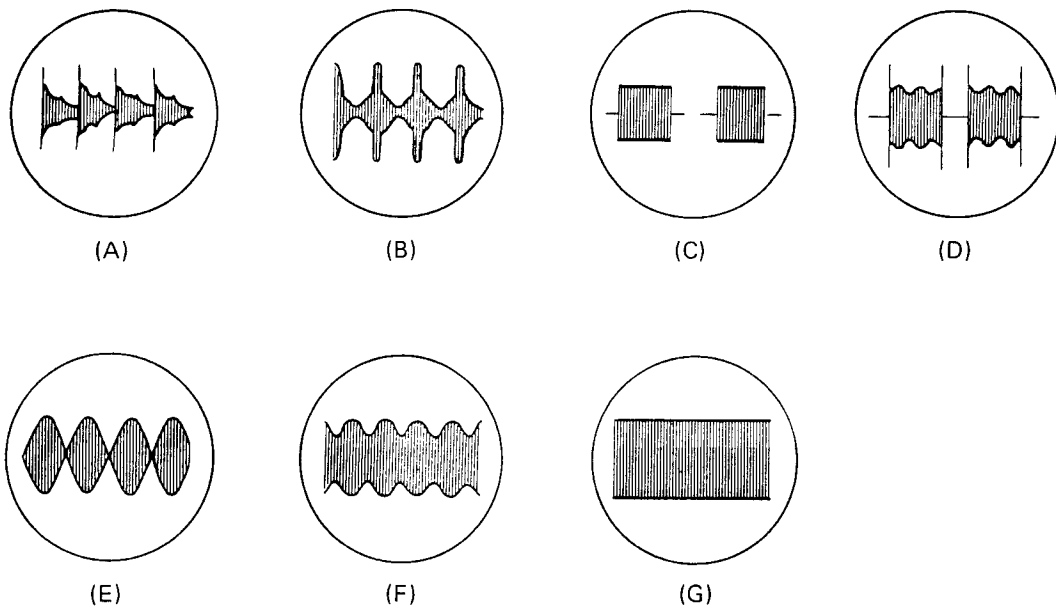

Figure 3.

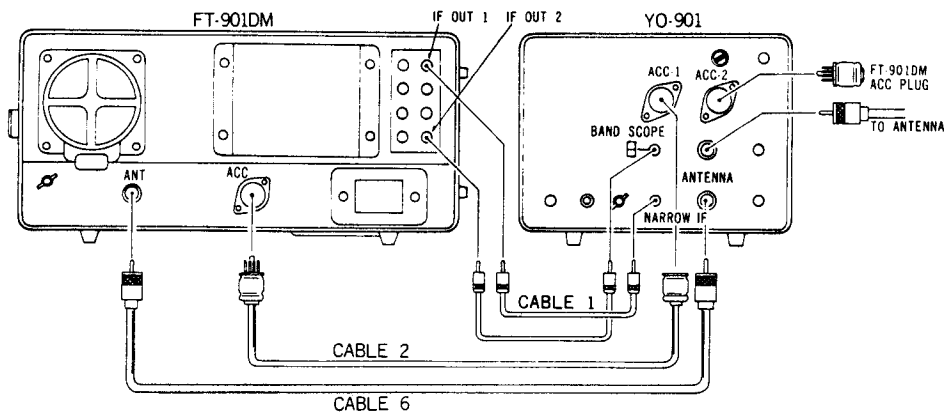

Figure 4

RECEIVER MONITOR

- (1) Make connections as shown on page 9 , Figure 4.
- (2) Press the IF button for input to the vertical amplifier.
- (3) Set the MODE switch to AUTO or BAND SCOPE.
- (4) As you tune the band, set the V. GAIN and VAR controls as required to produce a satisfactory display.

BAND SCOPE (OPTION)

When the Band Scope option is installed, monitoring of band activity can be accomplished, over a range of ± 10 kHz, ± 50 kHz, or ± 100 kHz. Connections are the same as those on page 9 .

- (1) Set the MODE switch to AUTO or BAND SCOPE.
- (2) Press the BAND SCOPE button.
- (3) To set the center frequency of the band scope, set the LIN-MARK ON-LOG switch to MARK ON, with the WIDTH switch at the 20 kHz/div position. Adjust the CENTER FREQ control for precise centering of the marker indication on the scale.

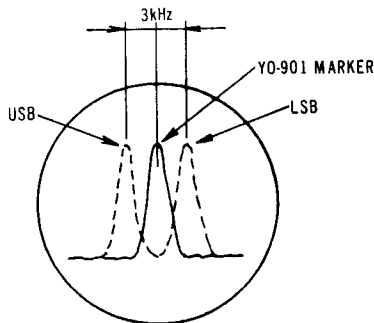

Figure 5

- (4) Now switch the WIDTH control to the 2 kHz div position, and adjust the CENTER FREQ control for a precise centering of the marker signal on the scale.
- (5) Now switch back to the 20 kHz/div scale. If the display jumps off center, adjust the H. POS control to recenter the display. Switch back and forth between the 2 kHz/div and 20 kHz/div scales, carefully adjusting the CENTER FREQ and H. POS controls until coincidence of the centers is accomplished.
- (6) Note that when changing modes on the FT-901DM that the carrier frequency will be 1.5 kHz offset from center for LSB and USB. This difference will, then, be 0.75 division.
- (7) The FT-901DM marker signal can also be used for centering the display. In this case, set the LIN-MARK ON-LOG switch to LIN or LOG, and switch on the FT-901DM marker. The 100 kHz calibration marks will be of slightly higher amplitude than the 25 kHz marks. Be sure that the preselector control on the FT-901DM is peaked on the marker signal. When the center frequency adjustment is complete, set the MARK ON switch to LIN or LOG.
- (8) When a strong signal enters the passband of the receiver, the AGC action of the receiver will cause the display to become lower in amplitude. For adjustment of the display amplitude, rotate the VAR control (or set the HI/LOW switch on the rear apron to LOW, to introduce a mismatch intentionally).

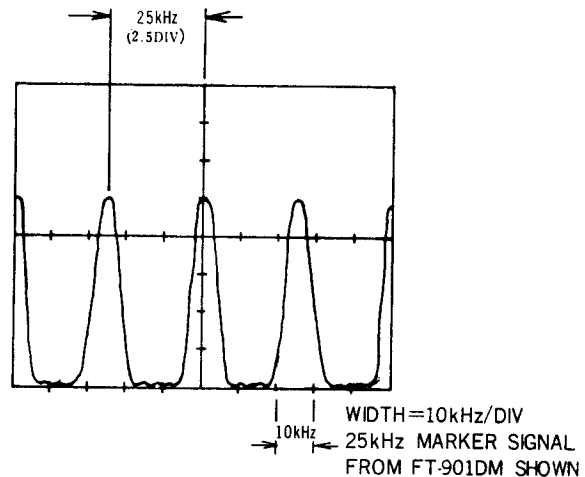

Figure 6

RF TRAPEZOID TEST

Set up the YO-901, FT-901DM, and FL-2100F as shown in Figure 8. Be certain to observe the precaution regarding proximity to the amplifier transformer. When using equipment other than the FT-901DM and FL-2100F, be certain not to exceed the power limitations stipulated earlier.

- (1) Place the MODE SWITCH TO THE TX MONITOR position.
- (2) Place the ENVEL/TRAP switch in the TRAP position
- (3) Place the V. INPUT switch in the IF position.
- (4) Activate the 1500 and 1900 Hz tone generator switches.
- (5) Activate the transmitter and amplifier, and adjust the H. GAIN control for the desired pattern height. Proper operation of the amplifier, and operating difficulties, are shown in Figure 7.

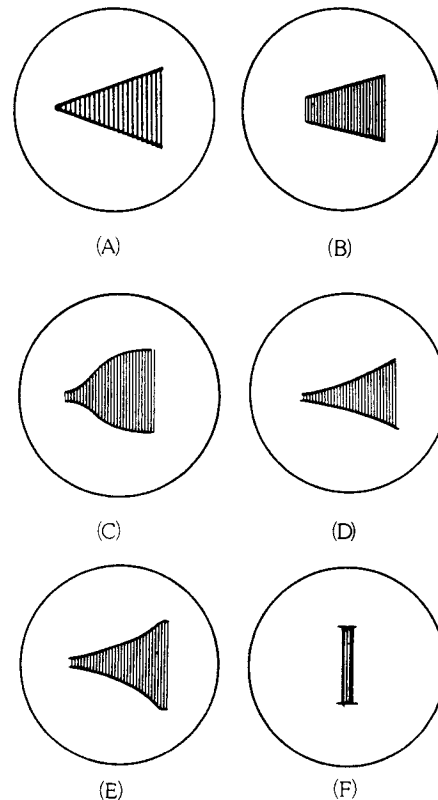

Figure 7

- (A) Good linearity. Proper amplifier operation.
- (B) Modulation less than 100%, but good linearity.
- (C) Non-linear pattern, indicating overdrive, insufficient antenna loading, grid current curvature, or regeneration.
- (D) Non-linear pattern, indicating regeneration or excessive grid bias.
- (E) Non linear pattern, with parasitic oscillation occurring on modulation peaks.
- (F) Unmodulated carrier.

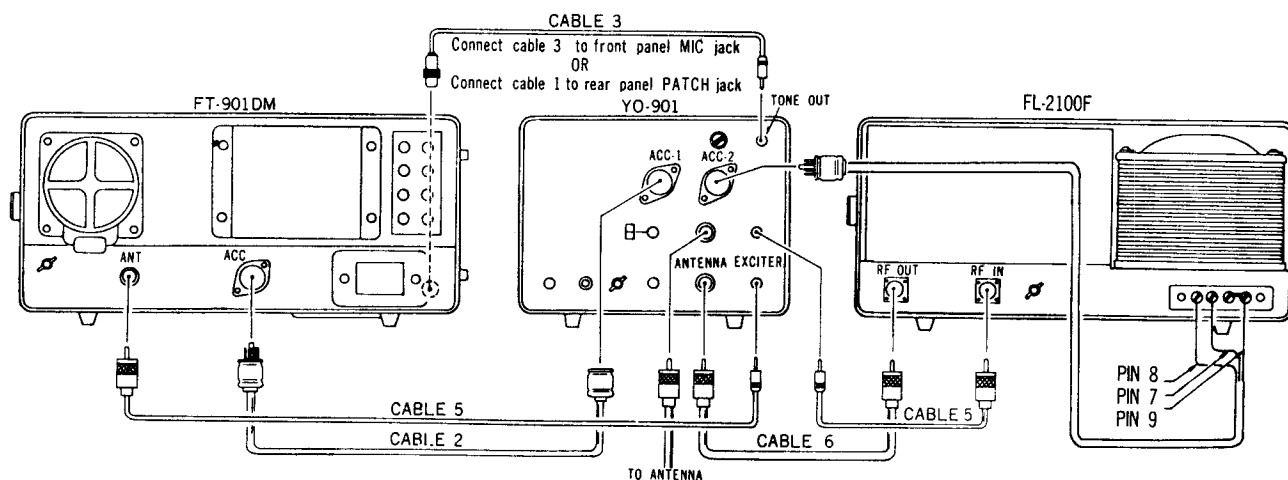

Figure 8

RTTY CROSS PATTERN TEST

Set up YO-901, terminal unit, and FT-901DM as shown in Figure 10.

- (1) Set the V. INPUT to AF.
- (2) Set the SWEEP FREQ control to EXT (RTTY). Be certain that the INTENSITY control is set to a low level, as RTTY patterns are often displayed for long periods of time, with little or no change. High intensity under these conditions can cause burning of the CRT phosphor.
- (3) The MARK and SPACE outputs from the terminal unit should be adjusted for equal levels when the received signal is properly tuned in. In order to accomplish this, alternately inject the MARK and SPACE signals into the vertical input of the YO-901, and adjust the balance potentiometer of the terminal unit until an equal height is obtained for both MARK and SPACE.
- (4) Now set the V. GAIN and H. GAIN controls on the YO-901 for a symmetrical cross pattern. Once the desired pattern has been achieved, the gain controls on the YO-901 should not be changed.

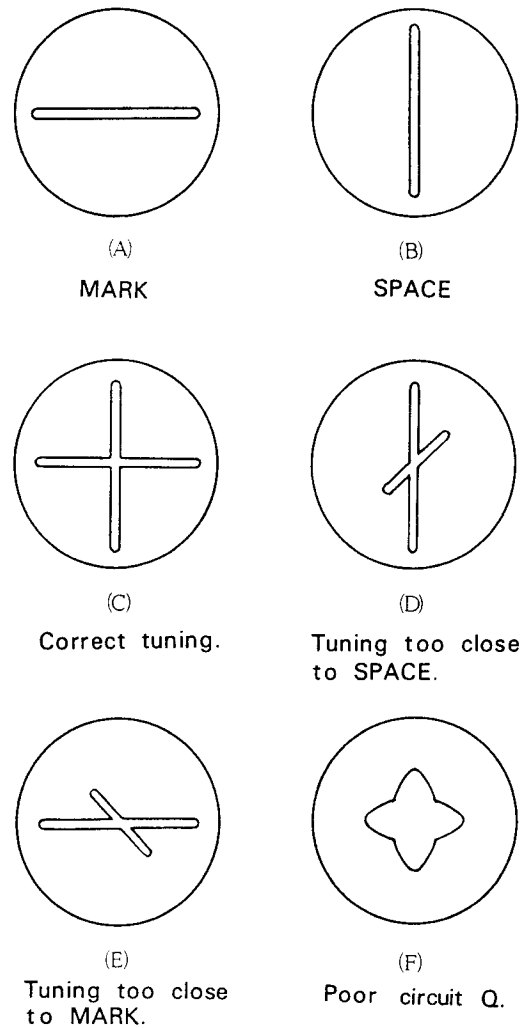

Figure 9

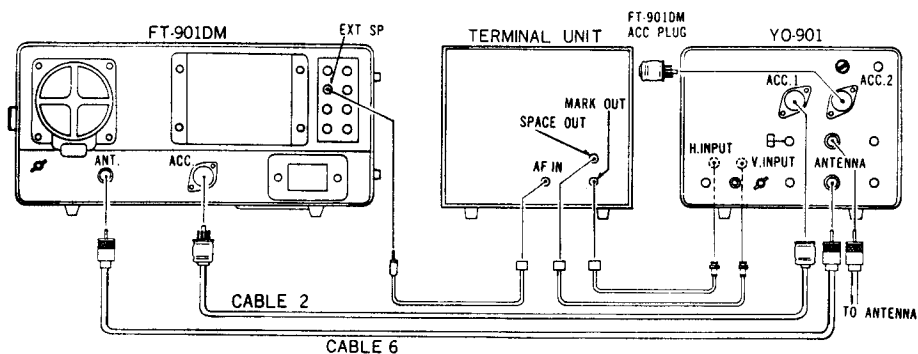
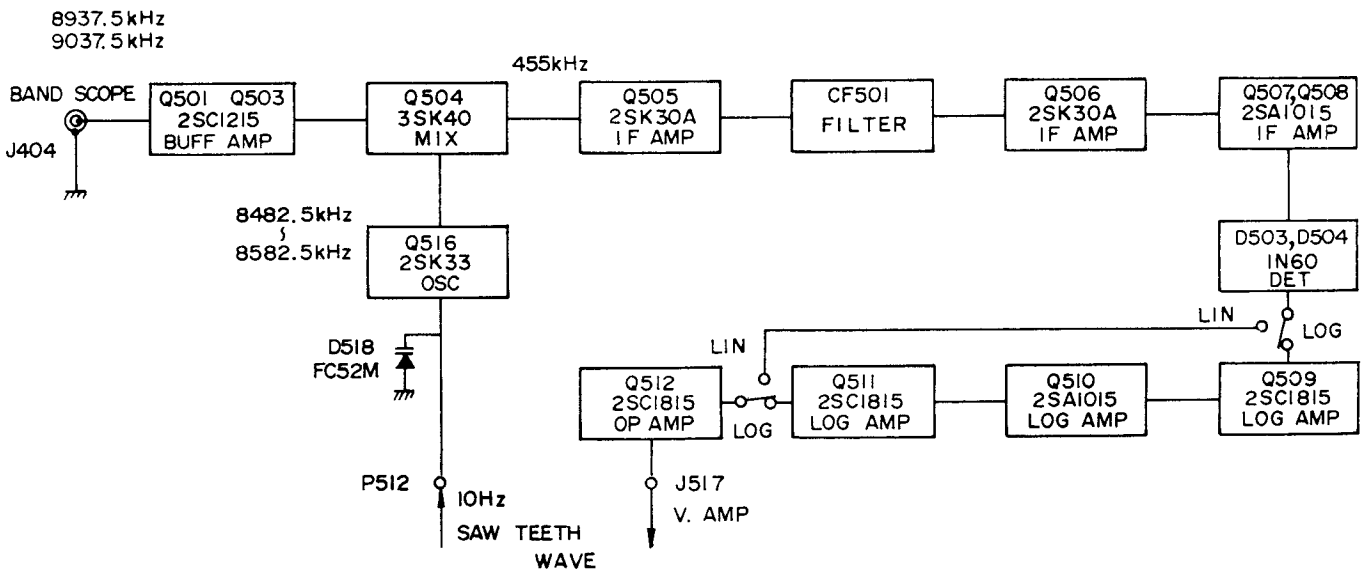
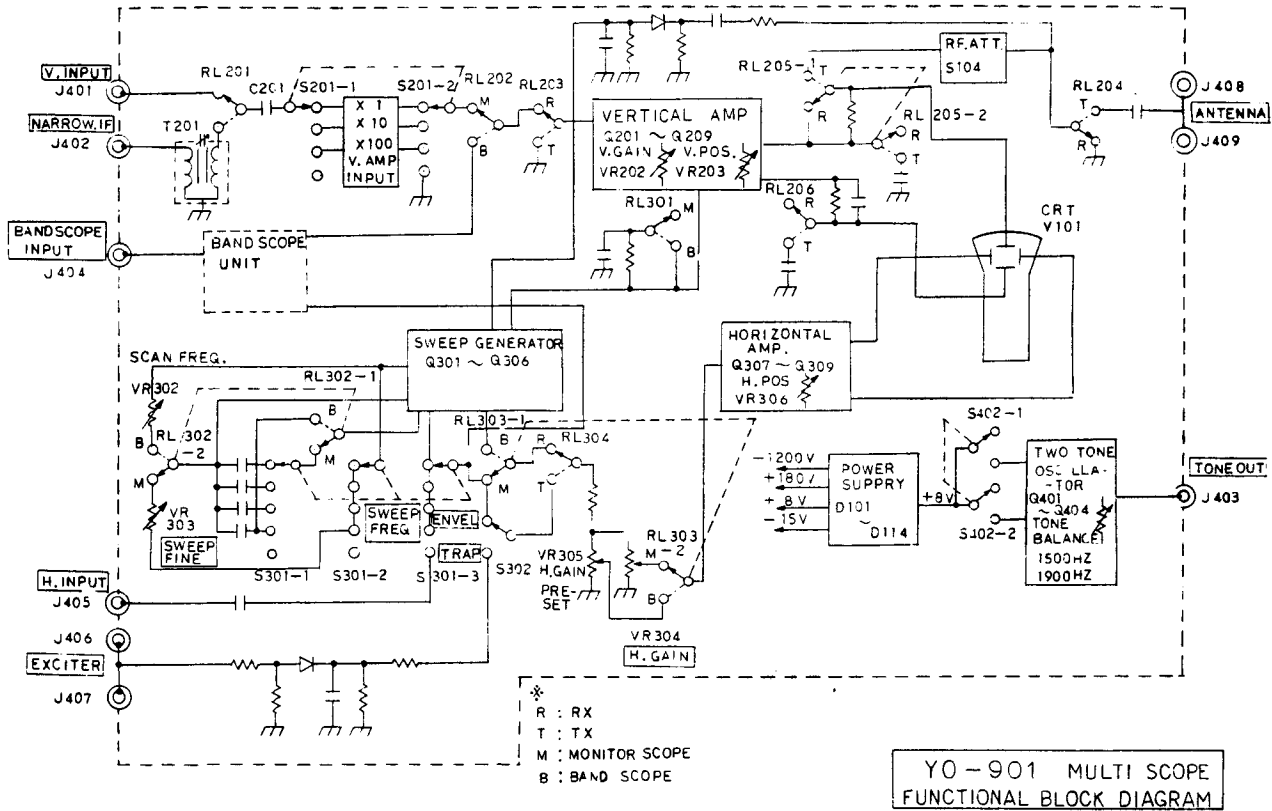

Figure 10

GENERAL OSCILLOSCOPE TESTING

This instrument can be used as an oscilloscope, with a sweep range of up to 100 kHz. The useful operating range of the scope is 2 Hz–4 MHz (–3 dB), and 8.9 MHz–10.7 MHz.

For oscilloscope use, place the V. INPUT switch to the AF position, connect the test cable to the V. INPUT terminal on the front panel of the YO-901, and adjust the V. GAIN, VAR, SWEEP FREQ, and FINE controls for the desired display.



CIRCUIT DESCRIPTION

Please refer to the block diagram, as well as the schematic diagram, while following the description of the circuitry employed in the YO-901 Multi-scope.

VERTICAL AMPLIFIER

The input signal to the vertical amplifier is applied to the V. INPUT jack J₄₀₁, the IF monitor input jack (NARROW IF) J₄₀₂, or the BAND SCOPE INPUT jack, J₄₀₄. The V. INPUT and BAND SCOPE switches perform the required switching.

The signal applied to J₄₀₁ or J₄₀₂ is fed through RL₂₀₁ to an attenuator, controlled by S₂₀₁, as well as the VAR potentiometer, for setting the input level. When S₂₀₁ is set to the GND position, the input is grounded.

The preset input signal is then fed through Q₂₀₁ and Q₂₀₃ (2SC1815O) to the input amplifier, Q₂₀₂ (2SK30AY), which also transforms the input high impedance to a low impedance for the following stage. Q₂₀₁ and Q₂₀₃ clip the input signal peaks, providing protection against high input voltages.

The output from Q₂₀₂ is then applied to a differential amplifier, consisting of Q₂₀₄ and Q₂₀₅ (2SC1215), which balances the signal for delivery to push-pull buffer amplifiers Q₂₀₆ and Q₂₀₇ (2SC1215). The signal is further amplified by the vertical amplifier, Q₂₀₈ and Q₂₀₉ (2SC1012A), for delivery to the vertical deflection electrodes (Y+ and Y-) of the cathode-ray tube, V₁₀₁ (C312P1).

HORIZONTAL AMPLIFIER

The horizontal signal selected by the SWEEP FREQ switch S₃₀₁ is amplified by Q₃₀₇ (2SK30AY), which converts the high input impedance to a low output impedance. The signal is then further amplified by Q₃₀₈ and Q₃₀₉ (2SC1514), for delivery to the horizontal deflection electrodes, X+ and X-, of V₁₀₁.

TRANSMITTER MONITOR

A portion of the transmitter output signal, connected through the rear apron ANTENNA

jacks, is sampled through C₂₁₁, and delivered through the INPUT LEVEL switch S₁₀₄ to the CRT vertical deflection plate. The RF voltage is sensed by envelope detector D₂₀₁ (1N60), for synchronization of the sweep generator, thus providing stable signal display on the CRT screen.

When the exciter output is fed through the EXCITER jacks J₄₀₆ and J₄₀₇, and the output of the linear amplifier is fed through the ANTENNA jack J₄₀₈ and J₄₀₉, a portion of the exciter signal is sensed by envelope detector D₃₀₁ (1N60). The signal is then fed to the horizontal deflection plate. The linear amplifier signal is sampled and fed to the vertical deflection plate. Thus, when the ENVEL/TRAP switch is placed in the TRAP position, a trapezoidal display will be provided, allowing adjustment of the amplifier for maximum linearity.

SWEEP GENERATOR

A saw-tooth sweep signal is produced by multivibrator Q₃₀₄ and Q₃₀₅ (2SC752GO). The saw-tooth signal is then amplified by the amplifier chain, consisting of Q₃₀₄, Q₃₀₅, and Q₃₀₆ (2SC1815O), and fed through the SWEEP FREQ switch and the SWEEP FINE control to the horizontal amplifier.

The sweep frequency may be varied continuously over the range of 10 Hz to 100 kHz.

A portion of the vertical signal is fed to buffer amplifier Q₃₀₁ (2SK30AY), the output signal of which is used for synchronization of the sweep frequency.

TWO-TONE GENERATOR

Oscillators Q₄₀₂ and Q₄₀₄ (2SK30AGR), configured in a Wien-bridge circuit, provide sine wave signals at 1900 and 1500 Hz, respectively. The bias voltage is stabilized by Q₄₀₁ and Q₄₀₃ (2SA733P), and the output level for each tone is set by VR₄₀₁ and VR₄₀₂. The rear apron TONE BALANCE control, VR₄₀₃, is used for equalizing the tones. Q₄₀₅ (2SC1815O) acts as a buffer amplifier, which delivers the output signal to the rear apron TONE OUT jack.

REMOTE SWITCH(NG)

When using the convenient interconnections to the FT-901DM series of transceivers, the YO-901 will provide automatic TX/RX switching of the scope display mode.

RL₂₀₁ provides switching between the V. INPUT jack and the NARROW IF jack.

Switching between the optional band scope and the TX monitor is accomplished by RL₂₀₂, RL₃₀₁, RL₃₀₂, and RL₃₀₃.

Switching between TX and RX modes is provided by RL₂₀₃–RL₂₀₆ and RL₃₀₄.

BAND SCOPE (OPTION)

When the optional band scope unit is installed, the wide-band IF signal from the FT-901 IF OUT-2 jack is applied through HI/LOW impedance switch S₆₀₁ to the band scope circuit. The IF signal in the FT-901 is sampled prior to any IF filtering. The signal is then amplified by buffer Q₅₀₁, amplifier Q₅₀₂, and buffer Q₅₀₃ (2SC1215), and applied to gate 2 of mixer Q₅₀₄ (3SK40). A local oscillator signal generated by Q₅₁₆ (2SK33F) is fed to gate 1 of Q₅₀₄, resulting in an output signal of 455 kHz.

The YO-901 saw-tooth 10 kHz signal is used to control varactor diode D₅₁₈ (FC-52M). WIDTH switch S₆₀₃ sets the voltage level, allowing sweep widths of 2 kHz/div. 10 kHz/div. or 20 kHz/div.

The 455 kHz signal is then amplified by Q₅₀₅ (2SK30AGR) and fed through ceramic filter CF₅₀₁, which filters the wideband FT-901 IF signal for the band scope. The signal is then amplified by Q₅₀₆ (2SK30AGR), Q₅₀₇, and Q₅₀₈ (2SA1015), detected by D₅₀₃ and D₅₀₄ (1N60), and then delivered to the final amplifiers, Q₅₀₉ (2SC18150), Q₅₁₀ (2SA10150), and Q₅₁₁ (2SC1815) for delivery to the vertical deflection electrodes.

When the front panel LIN-MARK-LOG switch is in the LIN position, the output from the final amplifiers is fed to operational amplifier Q₅₁₂, to modify the display for the linear mode.

Q₅₁₇ (2SC18150) generates a marker signal of 8987.5 kHz, via crystal X₅₀₁. This signal is fed to gate 2 of Q₅₀₄ for calibration of the band scope.

POWER SUPPLY

The power transformer primary has a dual winding, allowing selection of a variety of AC supply voltages. The secondary has three windings, which deliver four different DC voltages, plus AC heater voltage to the cathode ray tube.

Diodes D₁₀₁–D₁₀₄ (SIR150) are configured in a full-wave doubler circuit, providing –1200 volts DC from the 470 volt winding of the power transformer; this voltage is used for the CRT. D₁₀₉ and D₁₁₀ (1S1830) provide 180 volts DC from a full-wave rectifier circuit, for the vertical and horizontal amplifiers.

The transistor supply voltages are provided by Q₁₀₃ (MC7915CP) (–15 V), Q₁₀₂ (μPC14308) (+8 V), and Q₁₀₁ (μPC14312H) (+12 V).

MAINTENANCE AND ALIGNMENT

The YO-901 has been carefully aligned and tested at the factory prior to shipment. With normal use, this instrument should not require other than the normal attention given to any electronic apparatus. Service, or replacement of major components, may require substantial realignment. However, should trouble arise, under no circumstances should realignment be attempted unless the operation of the YO-901 is fully understood, and the malfunction definitely traced to misalignment. Parts failures are most often to blame for sudden difficulties. Service work should only be performed by an experienced technician, using the proper test equipment.

WARNING

DANGEROUS HIGH VOLTAGES IN EXCESS OF 1200 VOLTS ARE PRESENT WITHIN THE CABINET. EXTREME CAUTION MUST BE EXERCISED WHEN THE CABINET IS REMOVED. BEFORE REMOVING THE CABINET, REMOVE THE POWER PLUG FROM THE WALL SOCKET. DISCHARGE THE HIGH VOLTAGE CAPACITORS BY SHORTING THE HIGH VOLTAGE LINE TO GROUND WITH AN INSULATED SCREWDRIVER AFTER THE POWER HAS BEEN REMOVED.

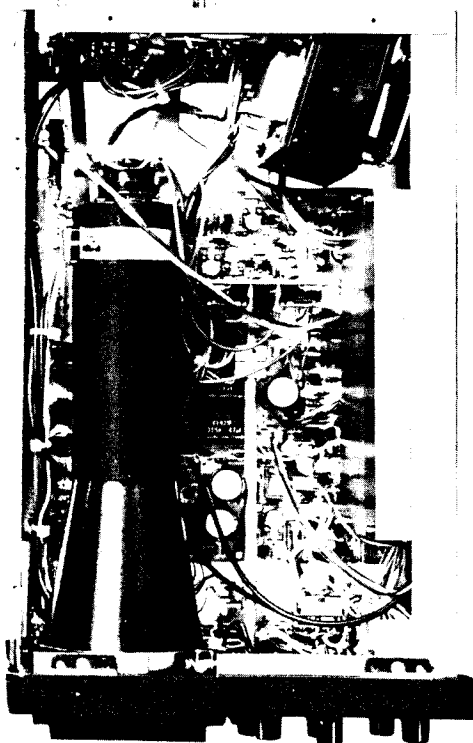

THESE VOLTAGES CAN BE FATAL. DO NOT WORK ON THIS UNIT WHEN TIRED.

1. Frequency Response Compensation of Vertical Attenuator (TC₂₀₁, TC₂₀₂)

Apply a pure square wave (50 Hz–5 kHz) to the vertical input, and observe the display on the cathode ray tube. Adjust TC₂₀₁ for the X₁₀ position, and TC₂₀₂ for the X₁₀₀ position, until the same pattern is obtained as in the case of the X₁ position.

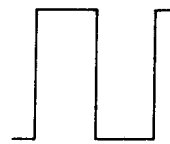

CORRECT

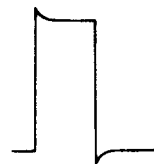

OVER-COMPENSATION



UNDER-COMPENSATION

2. Vertical Amplifier Balance (VR₂₀₂)

After the POWER switch is activated, wait 30 minutes. Check the position of the display while rotating the V. GAIN VAR and controls over its entire range. If the display moves up or down, adjustment of the balance is required.

Set the V. GAIN switch to GND, and the VAR control to the fully counterclockwise position. Adjust the V. POS control to set the display (horizontal line) in the center of the screen.

VR₂₀₁ should be adjusted so that there is no change in the position of the line as the VAR control is rotated fully clockwise.

Proper alignment may require several repetitions of the rotation-and-adjustment procedure.

3. TWO-TONE GENERATOR ALIGNMENT

VR₄₀₁ and VR₄₀₂ provide adjustment of the 1900 and 1500 Hz tones, respectively. VR₄₀₄ provides adjustment of the gain level of the two tones. VR₄₀₃ is the rear apron TONE PALANCE control, which will vary the level of the 1500 Hz tone.

4. BASE LINE ATTITUDE SETTING

If the scope trace line is not parallel to the base line, this deficiency may easily be corrected. Be certain to unplug the YO-901 from the supply, and discharge all high voltage capacitors before making the correction.

Loosen the restraining clamps at the front and rear of the cathode ray tube. Gently turn the tube slightly in its mount; do not force the unit, or it may break! Recheck the attitude of

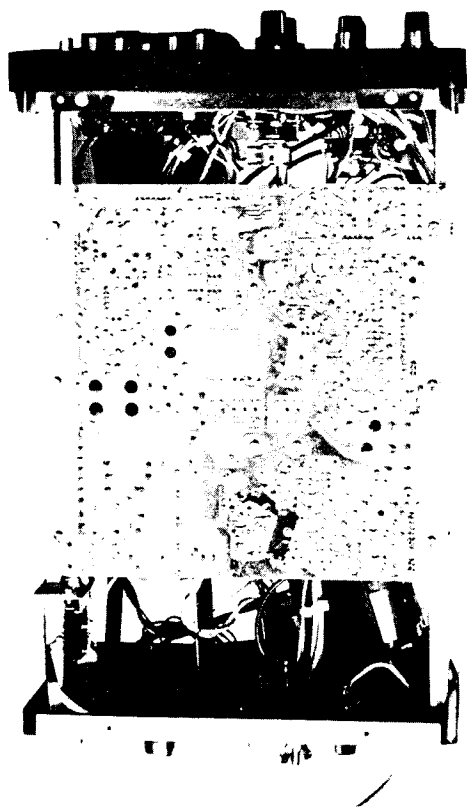

the line. If further adjustment is necessary, be certain to unplug the unit, and discharge the high voltage capacitors, before making each adjustment.

5. ASTIGMATISM (VR₁₀₁)

This adjustment will only be needed when the cathode ray tube is replaced. Set the FOCUS control to the 12 o'clock position. Adjust VR₁₀₁ for sharp focusing of the display.

6. H. GAIN PRESET (VR₃₀₅)

With the BAND SCOPE mode in operation, set VR₃₀₅ for a trace length of 11 divisions.

7. V. POS OFFSET (VR₂₀₄)

With the BAND SCOPE activated, set the V. POS control to the 12 o'clock position. Set the LIN-MARK ON-LOG switch to LIN. Adjust VR₂₀₄ so that the trace is precisely along the base line. In the IF position, the trace should be along the center line of the scope screen.

8. WIDTH (VR₅₀₆, VR₅₀₇, VR₅₀₈)

This alignment allows precise calibration of the band scope. Activate the band scope, and set the WIDTH control at the 2 kHz/div position.

Activate the FT-901DM marker, and align the marker display with the center of the screen. Now rotate the main tuning dial of the FT-901DM precisely 10.0 kHz. The display should move 5 divisions, to the edge of the screen. If the display did not move exactly 5 divisions, adjust VR₅₀₈ for the proper width, and repeat the test.

In the same manner, VR₅₀₇ will adjust the 10 kHz/div width, and VR₅₀₆ will adjust the 20 kHz/div scale.

9. LIN GAIN, LOG GAIN (VR₅₀₁, VR₅₀₂)

Place the LIN-MARK ON-LOG switch to LOG, and the VAR control fully clockwise. While receiving an S1 signal, set VR₅₀₂ for a full 8 division deflection on the screen. Now switch to the LIN mode, and receive an S5 signal. Adjust VR₅₀₁ for a deflection of 2 divisions.

10. BASE LINE BALANCE (VR₅₀₄)

In the BAND SCOPE mode, rotate the VAR control throughout its range, in the same manner as in alignment procedure #2. If the line changes position at all, VR₅₀₄ can be adjusted to eliminate this problem. Perform the alignment on either the LIN or LOG mode.

11. LOG OFFSET (VR₅₀₃)

Set the LIN-MARK-LOG switch to LOG, with the BAND SCOPE mode activated. Set the V. POS control to the 12 o'clock position. Adjust VR₅₀₃ so that the trace line is precisely along the base line, in the same manner as in alignment procedure #7.

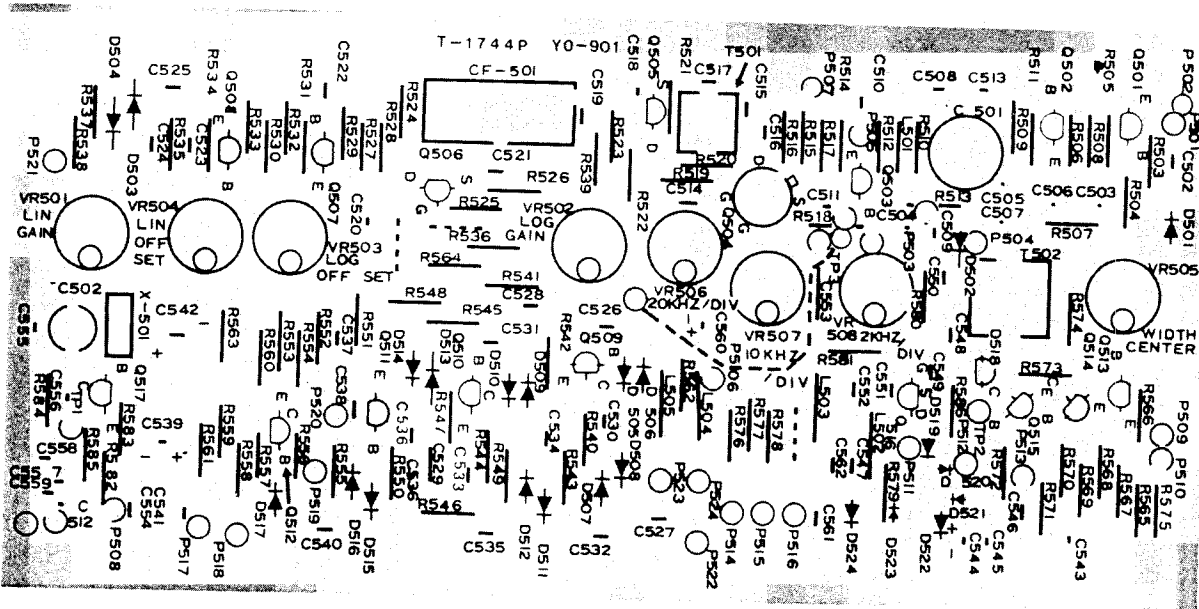
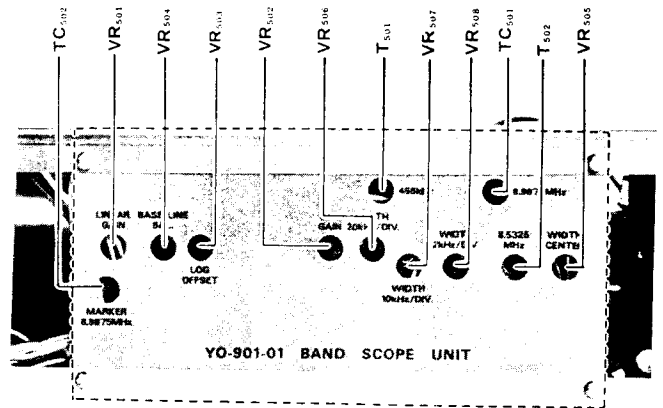

BAND SCOPE UNIT PARTS LOCATION

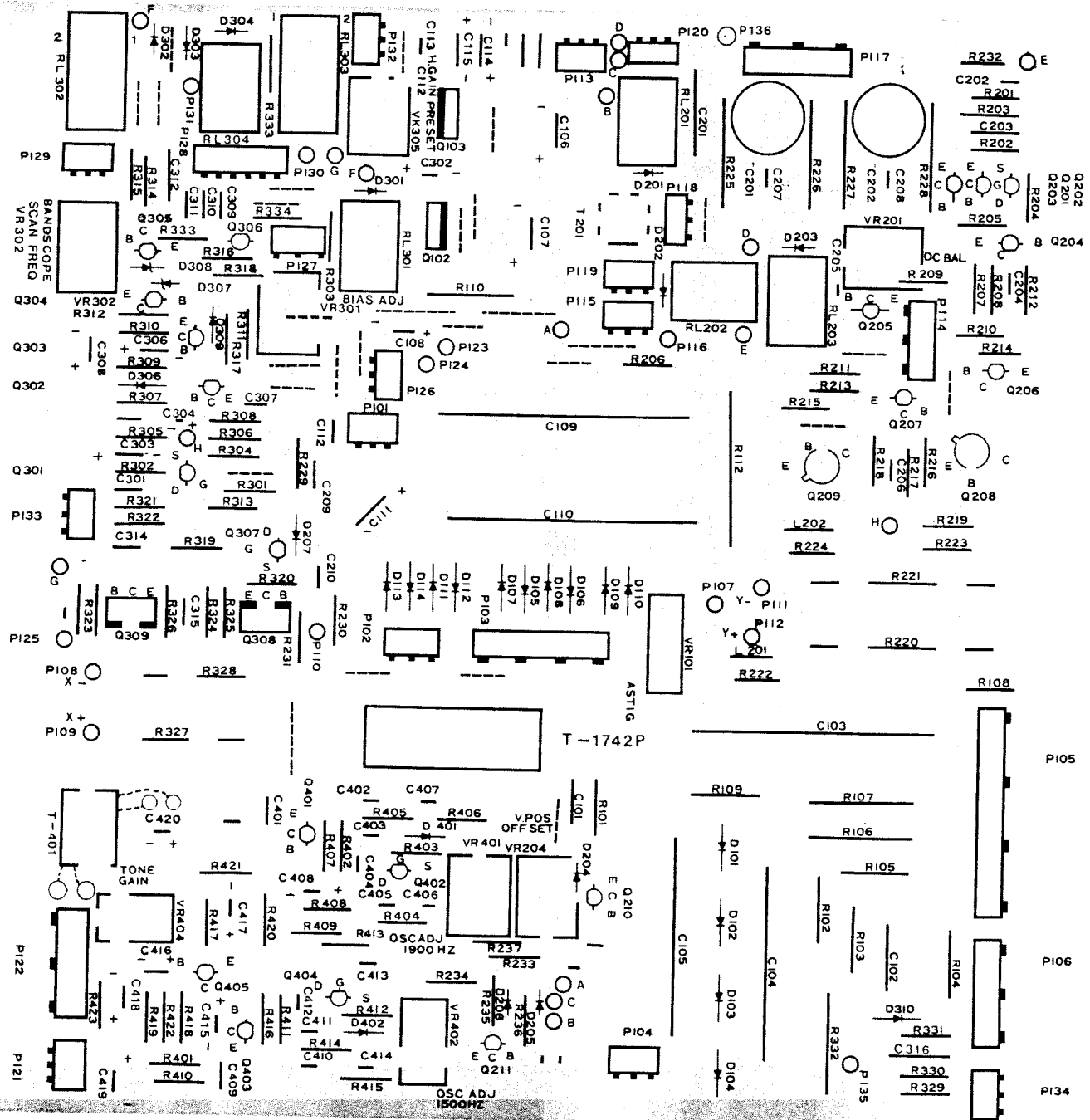

MAIN BOARD PARTS LOCATION

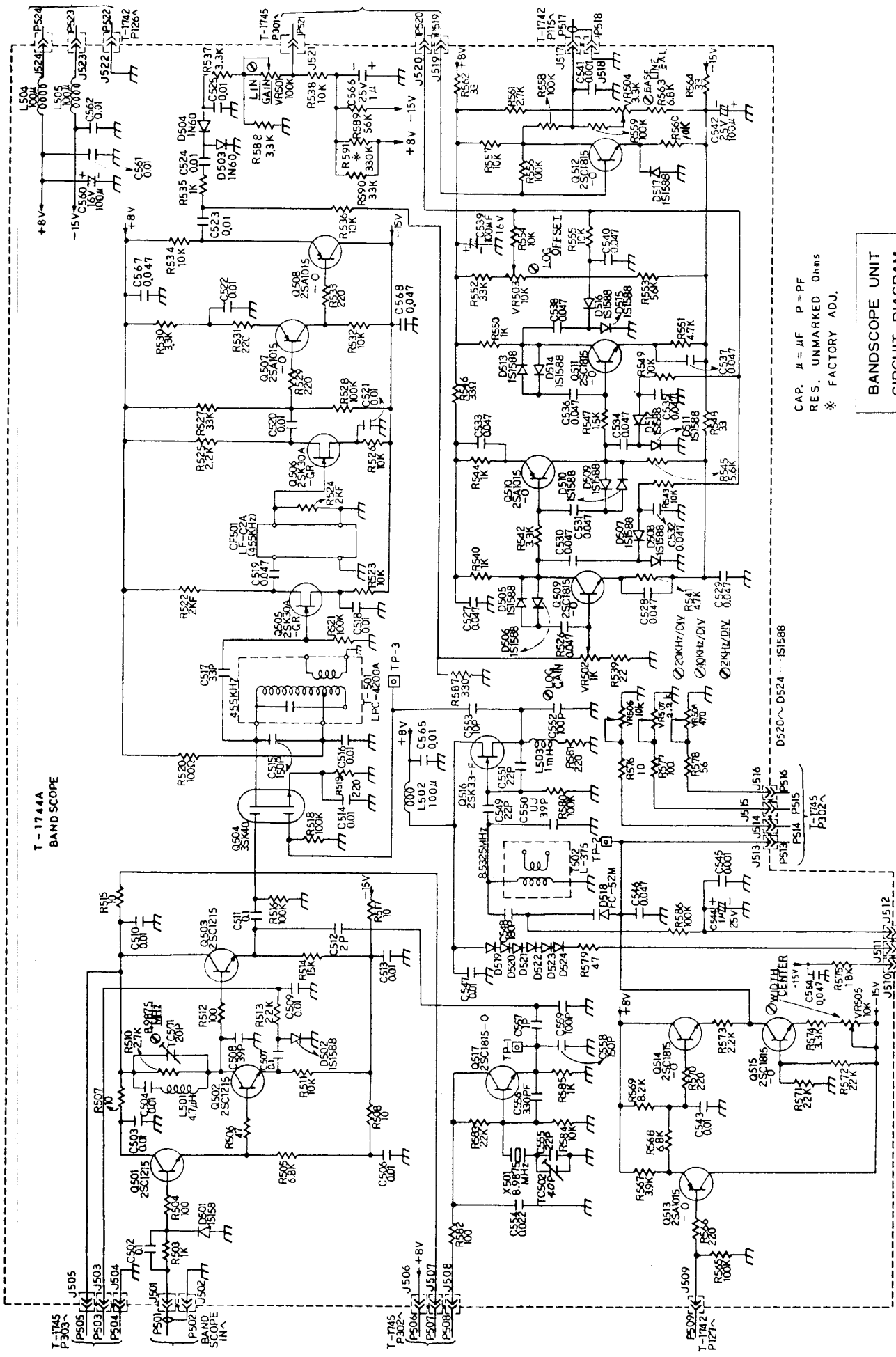

T-1744A
BAND SCOPE

CAP. μ = μ F P = PF
RES. UNMARKED Ohms
* FACTORY ADJ.

BANDSCOPE UNIT
CIRCUIT DIAGRAM

T-1745 P303 ~
P505 J505
P503 J503
P504 J504
P502 J502
P501 J501
BAND SCOPE IN ~

T-1745 P303 ~
P506 J506
P507 J507
P508 J508
+8V

P509 J509
T-1742 P172 ~
T-1745 P303 ~

T-1745 P303 ~
P512 J512
P510 J510
P511 J511
P513 J513
P514 J514
P515 J515
P516 J516
P517 J517
P518 J518
P519 J519
P520 J520
P521 J521
P522 J522
P523 J523
P524 J524
P525 J525
P526 J526
P527 J527
P528 J528
P529 J529
P530 J530
P531 J531
P532 J532
P533 J533
P534 J534
P535 J535
P536 J536
P537 J537
P538 J538
P539 J539
P540 J540
P541 J541
P542 J542
P543 J543
P544 J544
P545 J545
P546 J546
P547 J547
P548 J548
P549 J549
P550 J550
P551 J551
P552 J552
P553 J553
P554 J554
P555 J555
P556 J556
P557 J557
P558 J558
P559 J559
P560 J560
P561 J561
P562 J562
P563 J563
P564 J564
P565 J565
P566 J566
P567 J567
P568 J568
P569 J569
P570 J570
P571 J571
P572 J572
P573 J573
P574 J574
P575 J575
P576 J576
P577 J577
P578 J578
P579 J579
P580 J580
P581 J581
P582 J582
P583 J583
P584 J584
P585 J585
P586 J586
P587 J587
P588 J588
P589 J589
P590 J590
P591 J591
P592 J592
P593 J593
P594 J594
P595 J595
P596 J596
P597 J597
P598 J598
P599 J599
P600 J600
P601 J601
P602 J602
P603 J603
P604 J604
P605 J605
P606 J606
P607 J607
P608 J608
P609 J609
P610 J610
P611 J611
P612 J612
P613 J613
P614 J614
P615 J615
P616 J616
P617 J617
P618 J618
P619 J619
P620 J620
P621 J621
P622 J622
P623 J623
P624 J624
P625 J625
P626 J626
P627 J627
P628 J628
P629 J629
P630 J630
P631 J631
P632 J632
P633 J633
P634 J634
P635 J635
P636 J636
P637 J637
P638 J638
P639 J639
P640 J640
P641 J641
P642 J642
P643 J643
P644 J644
P645 J645
P646 J646
P647 J647
P648 J648
P649 J649
P650 J650
P651 J651
P652 J652
P653 J653
P654 J654
P655 J655
P656 J656
P657 J657
P658 J658
P659 J659
P660 J660
P661 J661
P662 J662
P663 J663
P664 J664
P665 J665
P666 J666
P667 J667
P668 J668
P669 J669
P670 J670
P671 J671
P672 J672
P673 J673
P674 J674
P675 J675
P676 J676
P677 J677
P678 J678
P679 J679
P680 J680
P681 J681
P682 J682
P683 J683
P684 J684
P685 J685
P686 J686
P687 J687
P688 J688
P689 J689
P690 J690
P691 J691
P692 J692
P693 J693
P694 J694
P695 J695
P696 J696
P697 J697
P698 J698
P699 J699
P700 J700
P701 J701
P702 J702
P703 J703
P704 J704
P705 J705
P706 J706
P707 J707
P708 J708
P709 J709
P710 J710
P711 J711
P712 J712
P713 J713
P714 J714
P715 J715
P716 J716
P717 J717
P718 J718
P719 J719
P720 J720
P721 J721
P722 J722
P723 J723
P724 J724
P725 J725
P726 J726
P727 J727
P728 J728
P729 J729
P730 J730
P731 J731
P732 J732
P733 J733
P734 J734
P735 J735
P736 J736
P737 J737
P738 J738
P739 J739
P740 J740
P741 J741
P742 J742
P743 J743
P744 J744
P745 J745
P746 J746
P747 J747
P748 J748
P749 J749
P750 J750
P751 J751
P752 J752
P753 J753
P754 J754
P755 J755
P756 J756
P757 J757
P758 J758
P759 J759
P760 J760
P761 J761
P762 J762
P763 J763
P764 J764
P765 J765
P766 J766
P767 J767
P768 J768
P769 J769
P770 J770
P771 J771
P772 J772
P773 J773
P774 J774
P775 J775
P776 J776
P777 J777
P778 J778
P779 J779
P780 J780
P781 J781
P782 J782
P783 J783
P784 J784
P785 J785
P786 J786
P787 J787
P788 J788
P789 J789
P790 J790
P791 J791
P792 J792
P793 J793
P794 J794
P795 J795
P796 J796
P797 J797
P798 J798
P799 J799
P800 J800
P801 J801
P802 J802
P803 J803
P804 J804
P805 J805
P806 J806
P807 J807
P808 J808
P809 J809
P810 J810
P811 J811
P812 J812
P813 J813
P814 J814
P815 J815
P816 J816
P817 J817
P818 J818
P819 J819
P820 J820
P821 J821
P822 J822
P823 J823
P824 J824
P825 J825
P826 J826
P827 J827
P828 J828
P829 J829
P830 J830
P831 J831
P832 J832
P833 J833
P834 J834
P835 J835
P836 J836
P837 J837
P838 J838
P839 J839
P840 J840
P841 J841
P842 J842
P843 J843
P844 J844
P845 J845
P846 J846
P847 J847
P848 J848
P849 J849
P850 J850
P851 J851
P852 J852
P853 J853
P854 J854
P855 J855
P856 J856
P857 J857
P858 J858
P859 J859
P860 J860
P861 J861
P862 J862
P863 J863
P864 J864
P865 J865
P866 J866
P867 J867
P868 J868
P869 J869
P870 J870
P871 J871
P872 J872
P873 J873
P874 J874
P875 J875
P876 J876
P877 J877
P878 J878
P879 J879
P880 J880
P881 J881
P882 J882
P883 J883
P884 J884
P885 J885
P886 J886
P887 J887
P888 J888
P889 J889
P890 J890
P891 J891
P892 J892
P893 J893
P894 J894
P895 J895
P896 J896
P897 J897
P898 J898
P899 J899
P900 J900
P901 J901
P902 J902
P903 J903
P904 J904
P905 J905
P906 J906
P907 J907
P908 J908
P909 J909
P910 J910
P911 J911
P912 J912
P913 J913
P914 J914
P915 J915
P916 J916
P917 J917
P918 J918
P919 J919
P920 J920
P921 J921
P922 J922
P923 J923
P924 J924
P925 J925
P926 J926
P927 J927
P928 J928
P929 J929
P930 J930
P931 J931
P932 J932
P933 J933
P934 J934
P935 J935
P936 J936
P937 J937
P938 J938
P939 J939
P940 J940
P941 J941
P942 J942
P943 J943
P944 J944
P945 J945
P946 J946
P947 J947
P948 J948
P949 J949
P950 J950
P951 J951
P952 J952
P953 J953
P954 J954
P955 J955
P956 J956
P957 J957
P958 J958
P959 J959
P960 J960
P961 J961
P962 J962
P963 J963
P964 J964
P965 J965
P966 J966
P967 J967
P968 J968
P969 J969
P970 J970
P971 J971
P972 J972
P973 J973
P974 J974
P975 J975
P976 J976
P977 J977
P978 J978
P979 J979
P980 J980
P981 J981
P982 J982
P983 J983
P984 J984
P985 J985
P986 J986
P987 J987
P988 J988
P989 J989
P990 J990
P991 J991
P992 J992
P993 J993
P994 J994
P995 J995
P996 J996
P997 J997
P998 J998
P999 J999
P1000 J1000

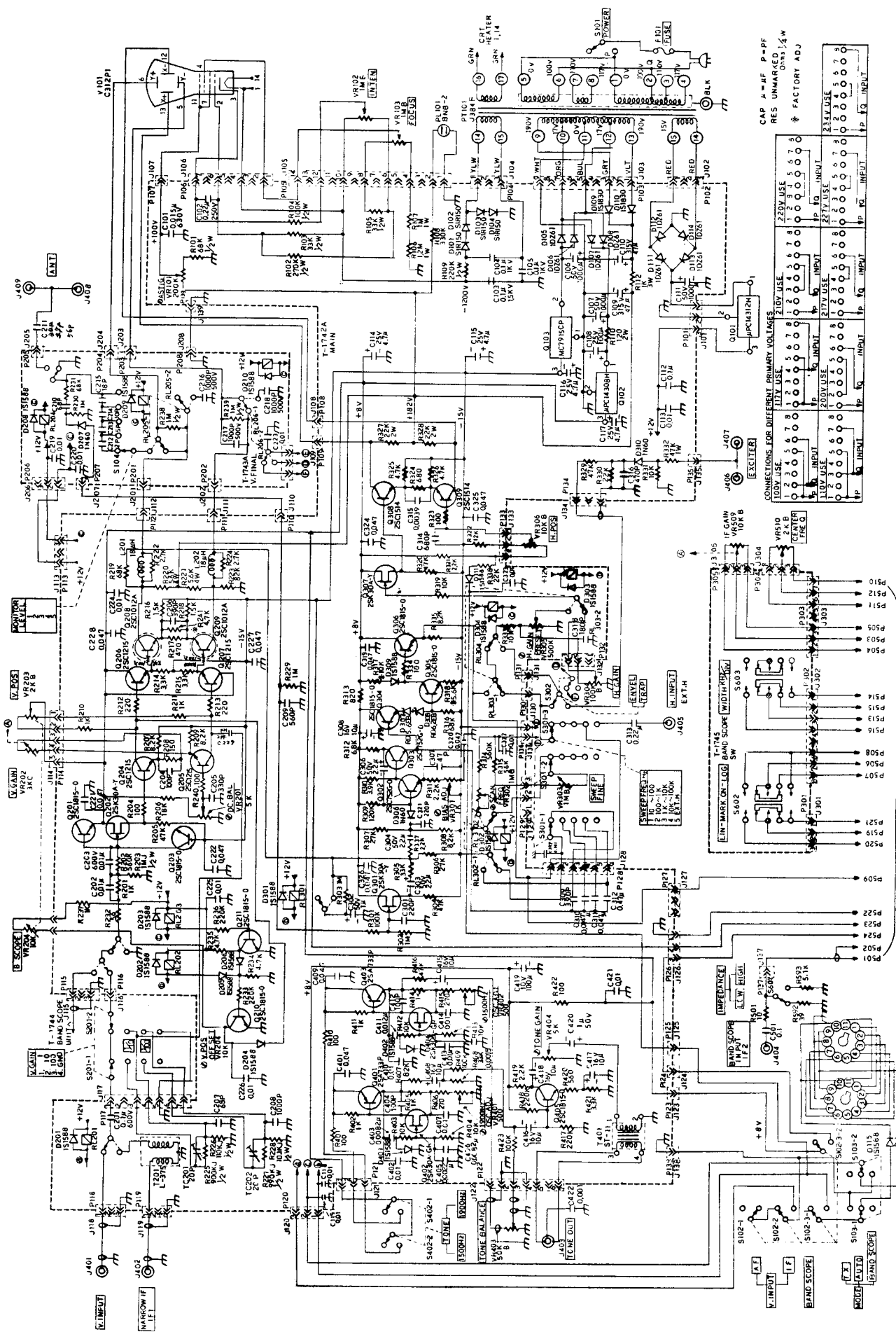

YO-901
CIRCUIT DIAGRAM

CONNECTIONS FOR DIFFERENT PRIMARY VOLTAGES

110V USE	120V USE	220V USE	250V USE
1 2 3 4 5 6 7 8	1 2 3 4 5 6 7 8	1 2 3 4 5 6 7 8	1 2 3 4 5 6 7 8
110V USE	120V USE	220V USE	250V USE
1 2 3 4 5 6 7 8	1 2 3 4 5 6 7 8	1 2 3 4 5 6 7 8	1 2 3 4 5 6 7 8
110V USE	120V USE	220V USE	250V USE
1 2 3 4 5 6 7 8	1 2 3 4 5 6 7 8	1 2 3 4 5 6 7 8	1 2 3 4 5 6 7 8
110V USE	120V USE	220V USE	250V USE
1 2 3 4 5 6 7 8	1 2 3 4 5 6 7 8	1 2 3 4 5 6 7 8	1 2 3 4 5 6 7 8

T-1744 BAND SCOPE UNIT

151088 PA4038.00 S4028.00
1-ACC-2